



Mass Flow Meter for Gases (MFM)

- Nominal flow ranges from 0.010 I_N/min to 80 I_N/min
- High accuracy
- Very fast response times
- Protection class IP65
- Optional: Fieldbus interface

Type 8702 can be combined with...



Type 8619

Multichannel program controller



Type 0330

3/2 or 2/2 way solenoid valve



Typ 6027

2/2 way plunger valve

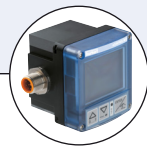

Typ 8611

eCONTROL

The mass flow meter (MFM) type 8702 is suited for measuring the mass flow of gases over a big flow range. The thermal MEMS sensor is located directly in the gas stream and therefore reaches very fast response times.

Type 8702 can optionally be calibrated for two different gases; the user can switch between these two gases. As electrical interfaces both, analog standard signals and fieldbuses are available.

Type 8712 is especially designed for use in harsh environments due to the high protection class.

Technische Daten	
Nominal flow range¹⁾ (Q_{nom})	0.01...80 I _N /min ²⁾ (ref. to N ₂)
Turn-down ratio	1:50, wider span on request
Operating gas	Neutral, non-contaminated gases, others available on request
Calibration gas	Operating gas or air with correcting function
Max. operating pressure (Inlet pressure)	Up to max. 10 bar (145 psi), depending on the orifice of the valve
Gas temperature	-10... +70 °C (-10... +60 °C with oxygen)
Ambient temperature	-10... +50 °C
Accuracy (after 1 min warm up time)	± 0.8% o.R. ± 0.3% F.S. (o.R.; F.S.: of full scale)
Repeatability	± 0.1% F.S.
Settling time (t_{95%})	< 300 ms
Materials	Body: Stainless steel Housing: PC (Polycarbonate) Seals: FKM, EPDM (others on request)
Port connection	G 1/4", NPT 1/4" or compression fitting
Electr. connection	Socket M16, round, 8 pin and socket D-Sub HD15, 15 pin With PROFIBUS-DP: Socket M12 5 pin (for IP65) or D-Sub 9 pin With CANopen: Plug M12 5 pin (for IP65) or D-Sub 9 pin
Operating voltage	24 V DC
Voltage tolerance	± 10%
Residual ripple	< 2%
Power consumption	max. 2.5 W (analog communicator) to 5 W (digital communicator)
Output signal (signal output)	0... 5 V, 0... 10 V, 0... 20 mA or 4... 20 mA Max. current, volt. output Max. load, current output 600 Ω
Digital communication via adapter possible:	RS232, Modbus RTU (via RS interface) RS485, RS422 or USB (see accessories table on p. 3)
Fieldbus option	PROFIBUS-DP, CANopen (D-Sub HD15 covered with sealed plate with fieldbus MFC)
Type of protection (with connected cables)	IP65
Dimensions [mm] (without fitting)	See drawings on p. 7-8
Total weight	1000 g
Mounting position	Horizontal or vertical
Light emitting diodes (Default, other functions programmable)	Indication for Power, Communication, Limit, Error
Binary inputs (Default, other functions programmable)	Three various functions programmable
Binary outputs (Default, other functions programmable)	Two relay outputs 1. Limit (Q _{nom} almost reached) 2. Error (i.e. sensor fault) Load capacity: max. 60 V, 1 A, 60 VA

¹⁾ The nominal flow value is the max. flow value calibrated which can be controlled. The nominal flow range defines the range of nominal flow rates (full scale values) possible.

²⁾ Index N: Flow rates referred to 1.013 bar and 0 °C.

Alternatively there is an Index S available which refers to 1.013 bar and 20 °C.

Measuring Principle

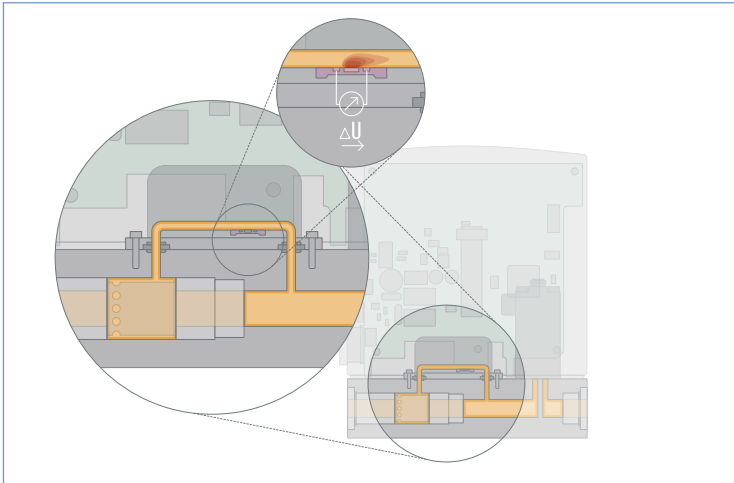

The actual flow rate is detected directly by a sensor placed in a bypass channel. This operates according to a thermal principle which has the advantage of providing the mass flow which is independent of pressure and temperature.

A small part of the total gas stream is diverted into a small, specifically designed bypassing channel which ensures laminar flow conditions. The sensor element is a chip immersed into the wall of this flow channel. The chip, produced in MEMS technology, contains a heating resistor and two temperature sensors (thermopiles) which are arranged symmetrically upstream and downstream of the heater. The differential voltage of the thermopiles is a measure of the mass flow rate passing the flow sensor. The calibration procedure effectuates a unique assignment of the sensor signal to the total flow rate through the device.

Pressure Loss Diagram (ref. to air, with 250µm inlet filter)

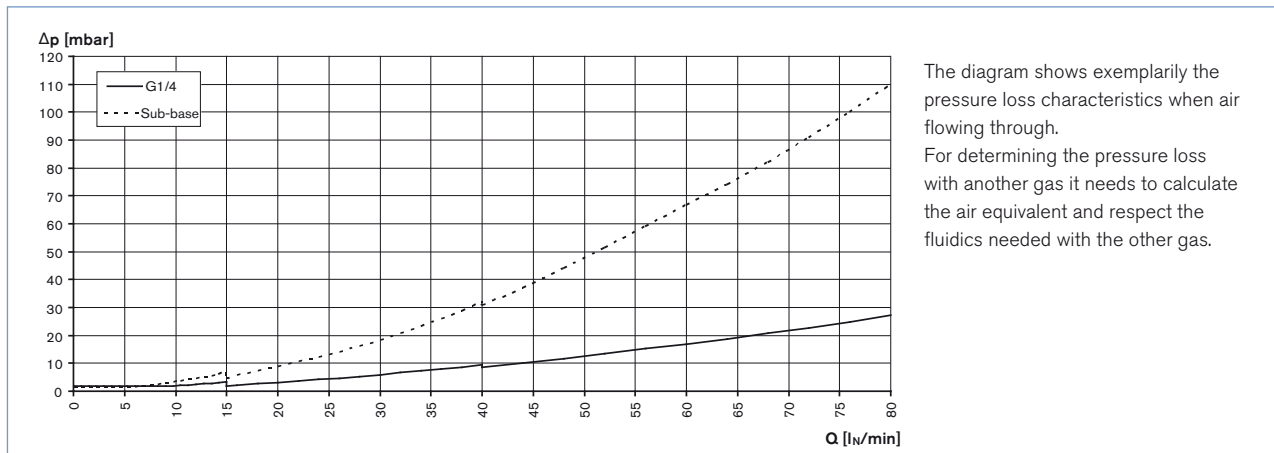

The diagram shows exemplarily the pressure loss characteristics when air flowing through. For determining the pressure loss with another gas it needs to calculate the air equivalent and respect the fluidics needed with the other gas.

Nominal Flow Range of Typical Gases

(other gases on request)

Gas	Min. Q_{nom} [l _N /min]	Max. Q_{nom} [l _N /min]
Argon	0.01	80
Helium	0.01	500
Carbon dioxide	0.02	40
Air	0.01	80
Methane	0.01	80
Oxygen	0.01	80
Nitrogen	0.01	80
Hydrogen	0.01	500

Notes regarding the selection of the unit

The decisive factors for the perfect functioning of an MFM within the application are the fluid compatibility, the normal inlet pressure and the correct choice of the flow meter range. The pressure drop over the MFM depends on the flow rate and the operating pressure.

▶ Please use the form on page 8 for the information about your specific requirements..

Ordering Chart for Accessories

Article	Article no.	
Connectors/Cables		
Round plug M16 8 pin (solder connection)	918299	
Round plug M16 8 pin with 5 m cable	787733	
Round plug M16 8 pin with 10 m cable	787734	
Plug D-Sub HD15 15 pin with 5 m cable	787735	
Plug D-Sub HD15 15 pin with 10 m cable	787736	
Adapters³⁾		
RS232 adapter for connection to a computer, connection with an extension cable (item no. 917 039)	654757	
Extension cable for RS232 9 pin socket/plug 2 m	917039	
RS422-Adapter (RS485 compatible)	666370	
USB-Adapter (Version 1.1, USB socket type B)	670696	
USB connection cable 2 m	772299	
Adapter for manual setting of bus address	667525	
Software MassFlowCommunicator	Download unter www.buerkert.com	
Accessories for Fieldbus	PROFIBUS DP (B-codiert)	CANopen (A-codiert)
M12-Plug ⁴⁾	918198	917115
M12-socket (coupling) ⁴⁾	918447	917116
Y-junction ⁴⁾	902098	788643
T-junction	918531	(auf Anfrage)
Shut-off resistor	902553	(auf Anfrage)
GSD-Datei (PROFIBUS), EDS-Datei (CANopen)	Download unter www.buerkert.com (unter Typ 8712)	

³⁾ The adapters serve mainly for initial operation or diagnosis. Those are not obligatory for continuous operation.

⁴⁾ The two M12 connectors as listed above cannot be used together on the same side of the Y-junction. At least one of the two M12 connection needs to be a prefabricated cable which uses typically a thinner connector.

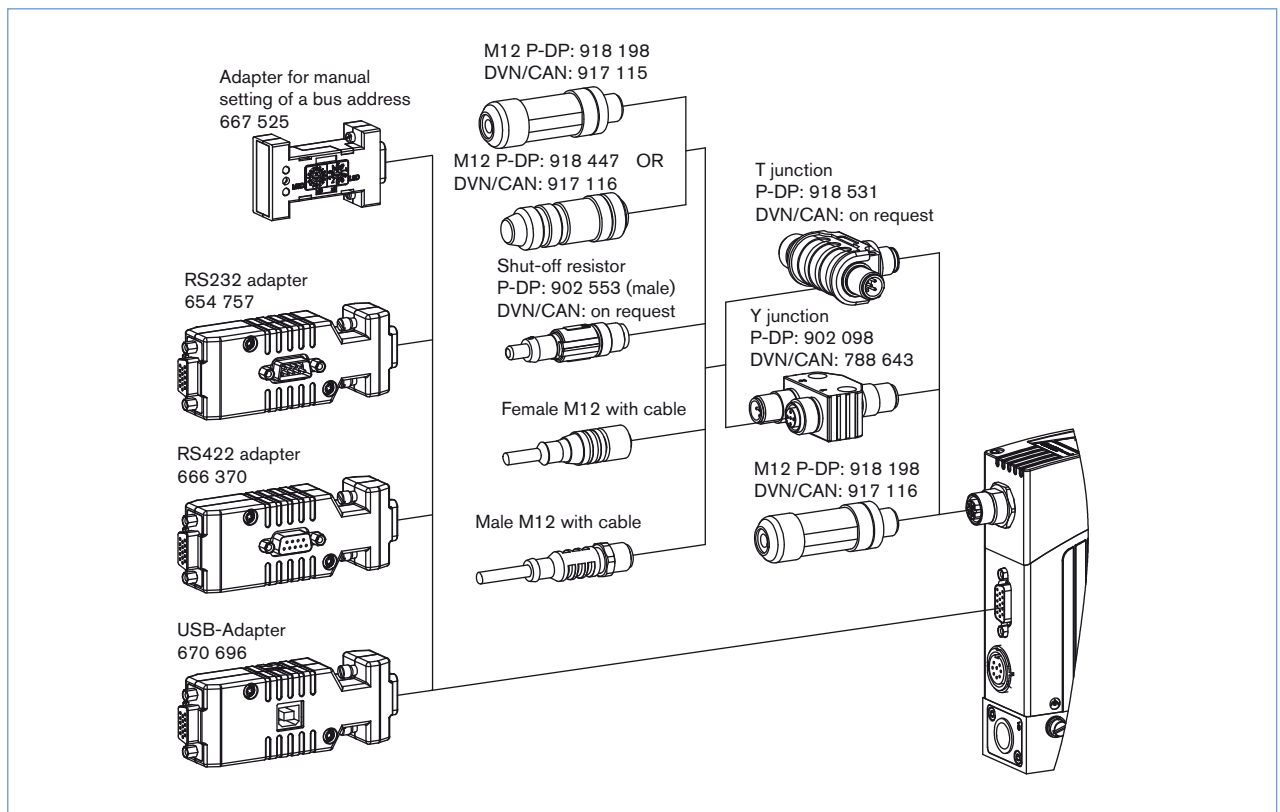

DTS 1000011286 EN Version: P Status: RL (released | freigegeben | valide) printed: 05.03.2018

Pin Assignment

DTS 1000011286 EN Version: P Status: RL (released | freigegeben | valide) printed: 05.03.2018

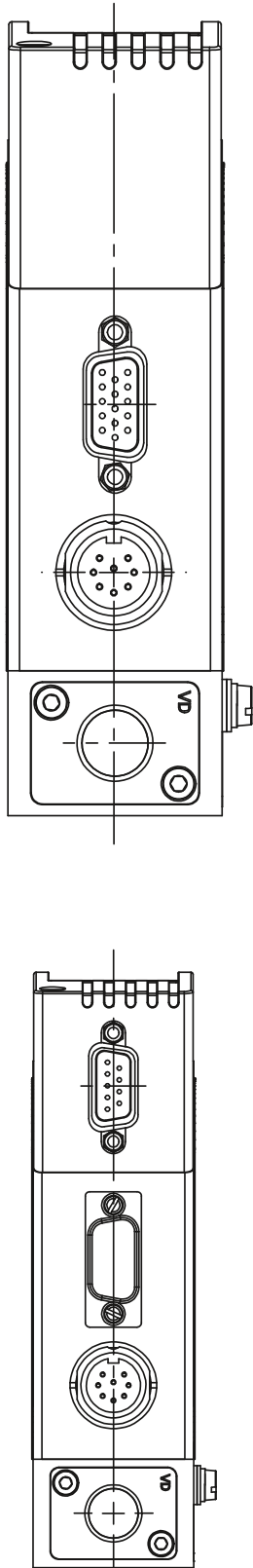

Socket D-Sub HD15

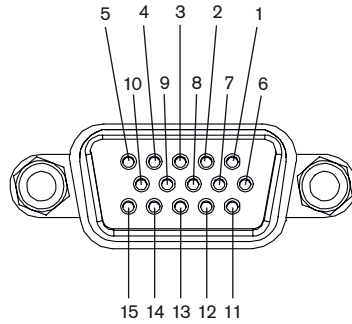

Pin	Assignment	
	Analogue Control	Bus control
1	N.C.	N.C. ⁵⁾
2	N.C.	N.C.
3	Actual value output +	N.C.
4	Binary input 2	
5	12 V-Output (only for internal company use)	
6	RS232 TxD (direct connection to computer)	
7	Binary input 1	
8	GND (for binary inputs)	
9	only company internal use (do not connect!)	
10	12 V-Output (only for internal company use)	
11	12 V-Output (only for internal company use)	
12	Binary input 3	
13	Actual value output GND	N.C.
14	RS232 RxD (direct connection to computer)	
15	DGND (for RS232-interface)	

⁵⁾N.C.: not connected (not used)

Note:

- Optional Pin 1 and 2 with bus version as transmitter input possible
- The cable length for RS232/ flow value signal is limited to 30 meters.

Socket M16, round, 8 pin

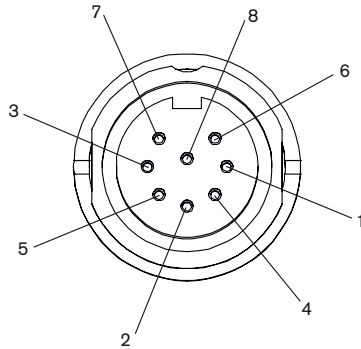

Pin	Assignment
1	24 V-Supply +
2	Relay 1 – reference contact
3	Relay 2 – reference contact
4	Relay 1 – normally closed contact
5	Relay 1 – normally open contact
6	24 V-Supply GND
7	Relay 2 – normally open contact
8	Relay 2 – normally closed contact

Socket D-Sub 9 pin

(only with fieldbus version)

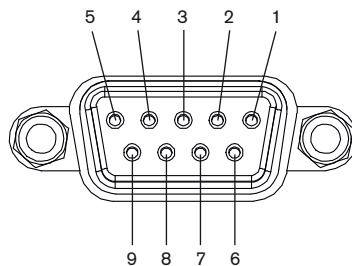

Pin	Assignment	
	PROFIBUS DP	CANopen
1	Shield	Shield
2	N.C.	CAN-L data line
3	RxD/TxD - P (B-line)	GND
4	RTS (control signal for repeater)	N.C.
5	GND	N.C.
6	VDD (only for termination resistor)	N.C.
7	N.C.	CAN-H data line
8	RxD/TxD - N (A-line)	N.C.
9	N.C.	N.C.

Pin Assignment (continued)

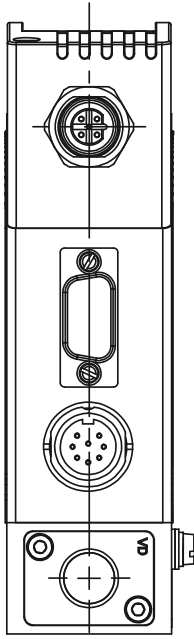

PROFIBUS DP – socket B-coded M12 (DPV1 max. 12 Mbaud)

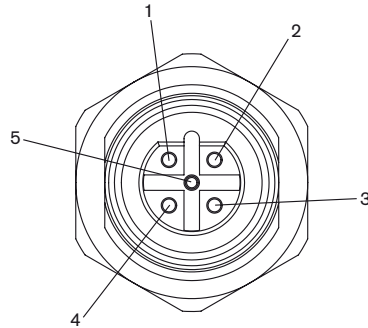

Pin	Assignment
1	VDD (only for termination resistor)
2	RxD/TxD – N (A-line)
3	DGND
4	RxD/TxD – P (B-line)
5	N.C.

CANopen – Plug A-coded M12

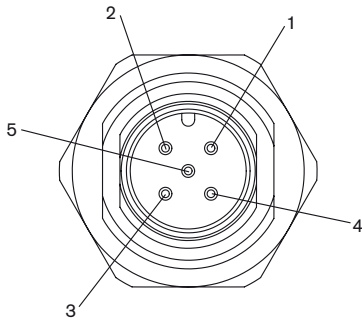

Pin	Assignment
1	Shield
2	N.C. ⁶⁾
3	DGND
4	CAN_H
5	CAN_L

⁶⁾ Optional configuration with 24 V DC possible for power supply via fieldbus connector. With this no power supply connection on round M16 plug needed.

Dimensions [mm]

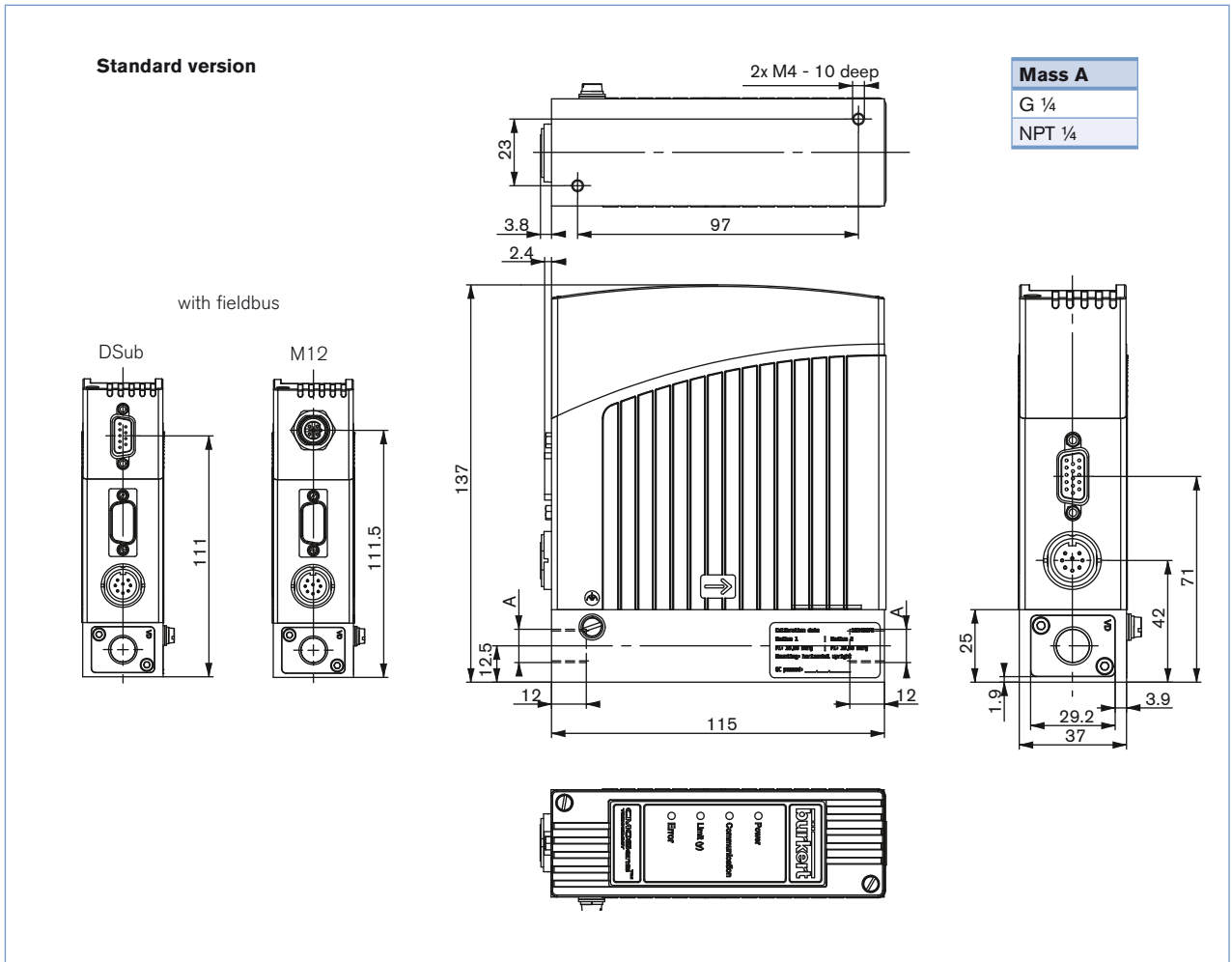

Dimensions [mm] (continued)

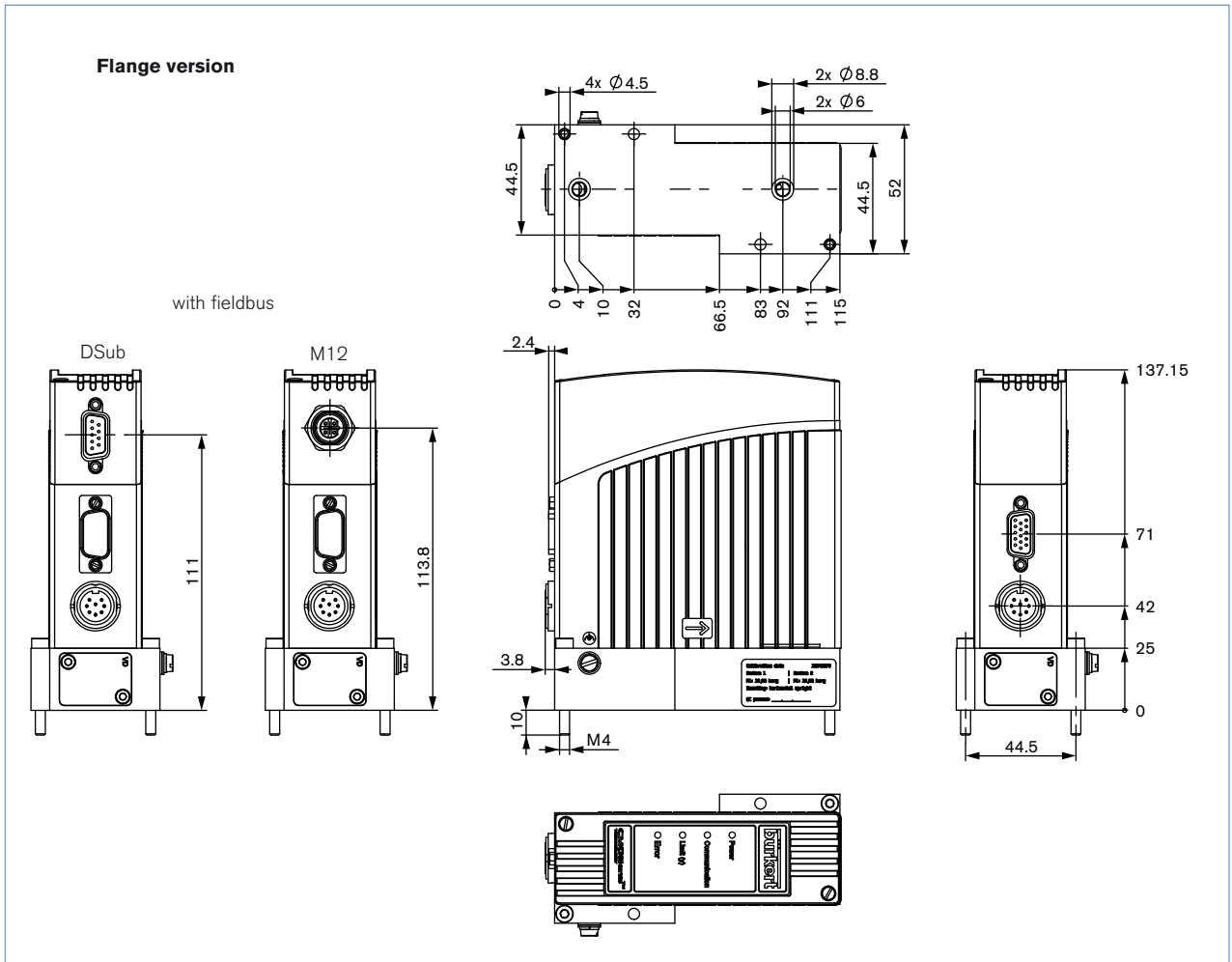

MFC/MFM-applications - Request for quotation

▶ Please complete and send to your nearest Bürkert sales centre

Company	Contact person
Customer No	Department
Address	Tel./Fax
Postcode/Town	E-mail

 MFC-Application MFM-Application Quantity Required delivery date

Medium data

Type of gas (or gas proportion in mixtures)

Density kg/m³⁽⁷⁾

Gas temperature [°C or °F] °C °F

Moisture content g/m³

Abrasive components/solid particles no yes, as follows:

Fluidic data

Flow range Q_{nom} Min. l_N/min⁽⁷⁾ l_S/min (slpm)⁽⁸⁾
 Max. m_N³/h⁽⁷⁾ kg/h
 cm_N³/min⁽⁷⁾ cm_S³/min (sccm)⁽⁸⁾
 l_N/h⁽⁷⁾ l_S/h⁽⁸⁾

Inlet pressure at Q_{nom} ⁽⁹⁾ $p_1 =$ bar(g) ■

Outlet pressure at Q_{nom} $p_2 =$ bar(g) ■

Max. inlet pressure P_{1max} bar(g) ■

MFC/MFM port connection

without screw-in fitting

¼" G-thread (DIN ISO 228/1)

¼" NPT-thread (ANSI B1.2)

with screw-in fitting (acc. to specification for pipeline)

mm Pipeline (external Ø)

inch Pipeline (external Ø)

Flange version

Installation

horizontal

vertical, flow upwards vertical, flow downwards

Ambient temperature °C

Material data

Body Aluminium Stainless steel

Housing Plastic Metal (not with type 8712/8702 and not with fieldbus)

Seal FKM EPDM

Electrical data

Signals for set point and actual value

with standard signal		with fieldbus	
Setpoint	actual value		
<input type="checkbox"/> 0 ... 5 V	<input type="checkbox"/> 0 ... 5 V	<input type="checkbox"/> PROFIBUS DP	<input type="checkbox"/> M12
<input type="checkbox"/> 0 ... 10 V	<input type="checkbox"/> 0 ... 10 V	<input type="checkbox"/> CANopen	<input type="checkbox"/> D-Sub
<input type="checkbox"/> 0 ... 20 mA	<input type="checkbox"/> 0 ... 20 mA		
<input type="checkbox"/> 4 ... 20 mA	<input type="checkbox"/> 4 ... 20 mA		

■ Please quote all pressure values as overpressures with respect to atmospheric pressure bar(ü)
 7) at: 1.013 bar(a) and 0 °C 8) at: 1.013 bar (a) and 20 °C 9) matches with calibration pressure

To find your nearest Bürkert facility, click on the orange box

www.buerkert.com

In case of special application conditions, please consult for advice.

Subject to alteration.
© Christian Bürkert GmbH & Co. KG

1803/8_EU-en_00891856